

A & -, ,

, -, , | E / |

A % % %

- | | :
- . B + g
- . 2
- : & + B / 1

- | | :
- . B + g
- !. 2 "
- | : & + B / 1

■ :
■

A & -, ,

H B

E B
B9 B6 - : H

A & -, , & B & B & B
; , . . - 11.20 cd

■ 动
A & -, , & ; ; & & - ; =: =; : ;

■ 动
A & -, , & & / & - . /

■ 动
A & -, , & & & ; : : ; ; -: -; . :

G

■ ; @
H A & -, , & ; ; & & % | - ; %: %; %: ;

■ @
H A & -, , & & / & % | - , % % /

■ @
H A & -, , & & & ; : : % | - ; ; %: %; . :

F

|

C +.

! 6+. B + :

! =6 . 6+. B :

! 6+. +

= !A; F " = +

H &-

&-

! . 6 - : "

|

I . 2,

= . 1,

. 2

. 2.

; . B 1

. B : . B + g

+ .

++.

+ / .

6 + " B + :

B :

I G & !C (: " C / D(

I G & !C (| " C . + D(

A & -, ,

; @ ! . 6 - : "

@ E B E B E
B B

| | | | |
|----|------|----|------|
| ; | , .. | -. | + |
| =: | -. / | . | + |
| =; | . / | 0 | 2 |
| : | 0 | 2 | +- + |
| ; | 2 | + | , , |

@ ! . 6 - : "

@

| | | |
|-----|------|-------|
| , ; | + . | ++ |
| -: | ++ | +, . |
| -; | +, . | + |
| ..: | +. . | + / . |

= @ ! . 6 - : "

@ = =

| | | |
|---|------|------|
| , | . 1, | . 1/ |
| - | . 1/ | . 12 |
| . | . 12 | . 2+ |
| / | . 2+ | . 2. |

A & -, ,

B

E

+ ; & , ;
;

;

,

, ;

& ! " 6 于

& ! " 6

B 6 ! "

. 6 - :

B

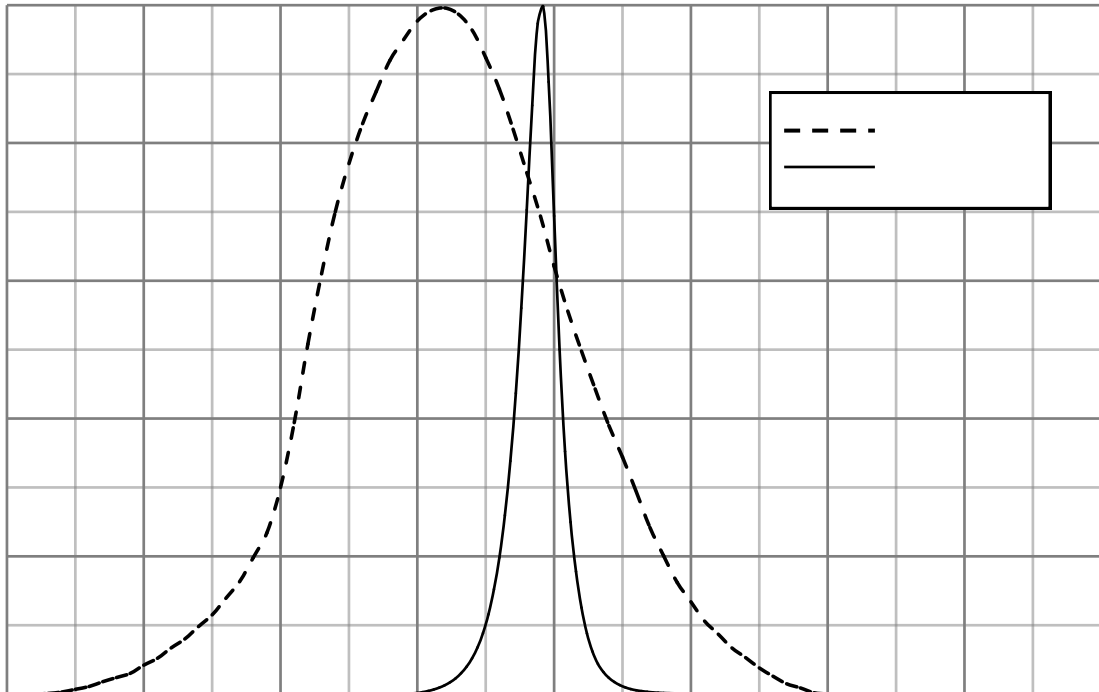

B 6 ! 6 +.

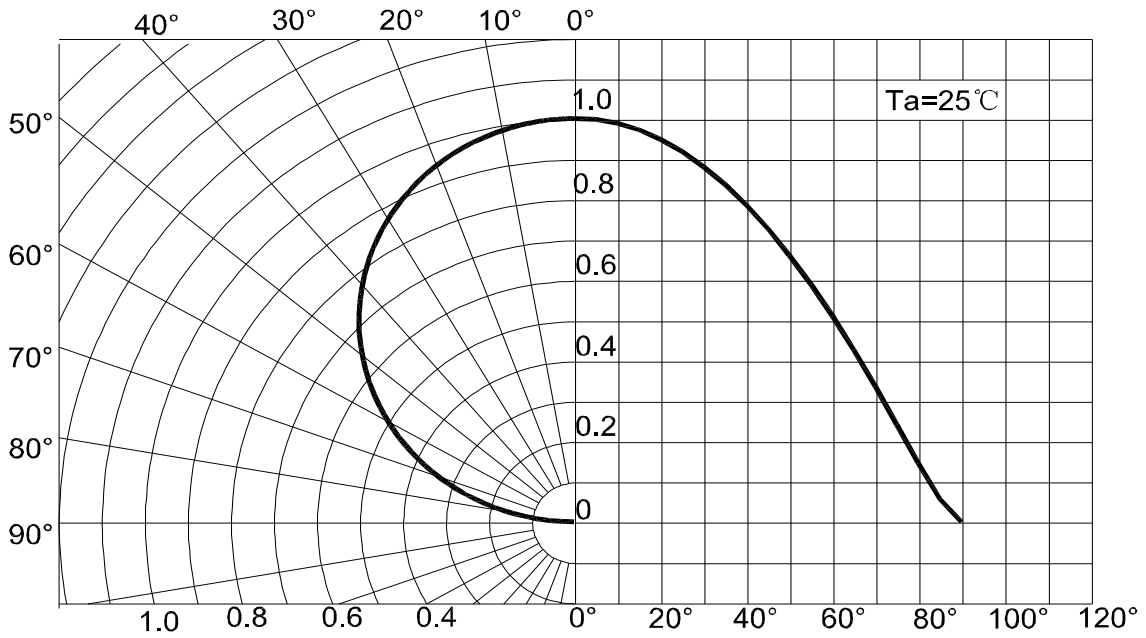

E B

B6 ! "

B(B! - : "6 !B'

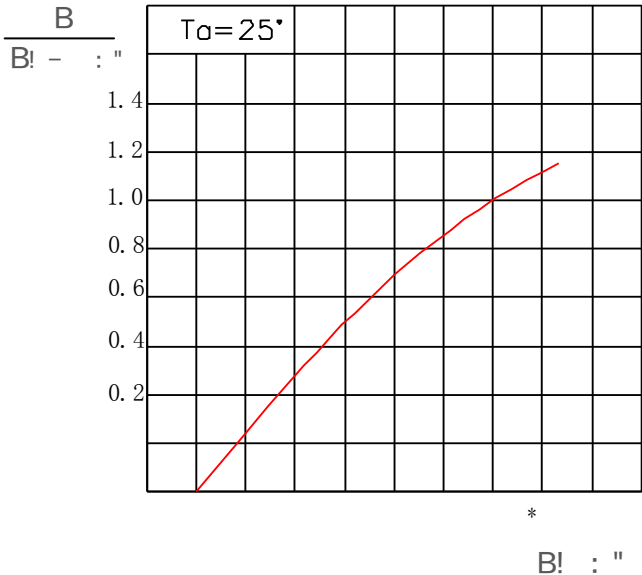
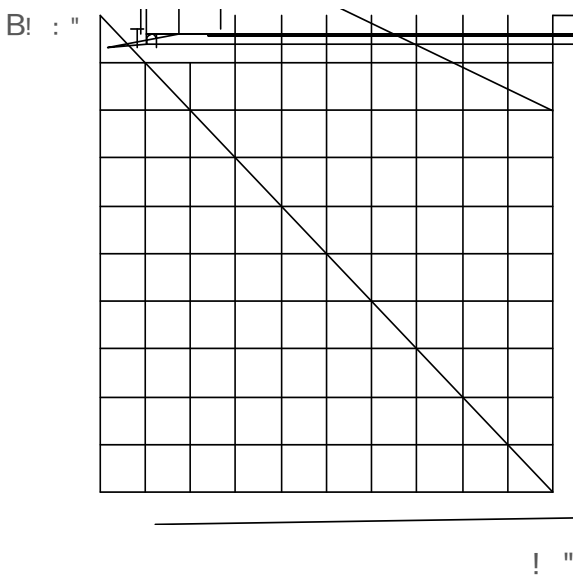

6 & 9" B6 - :

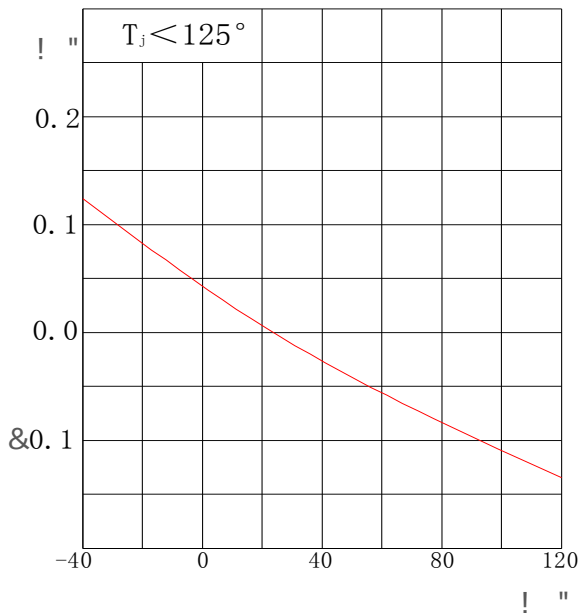

B(B 9" B6 - : E B

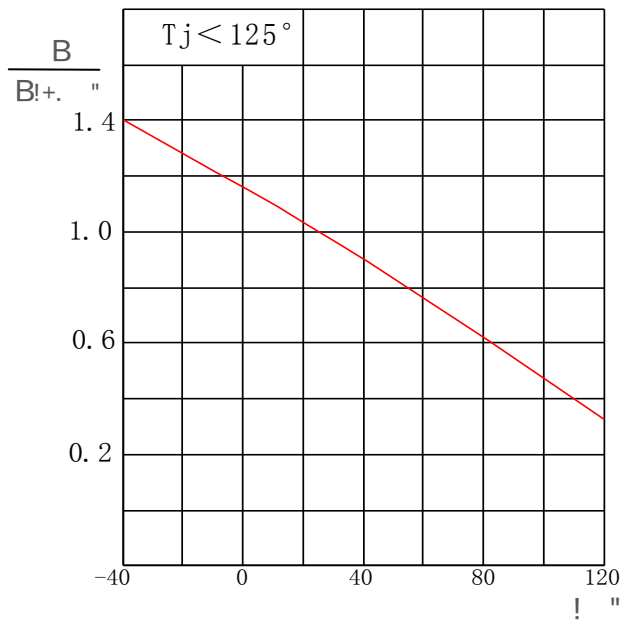

: B6 ! "

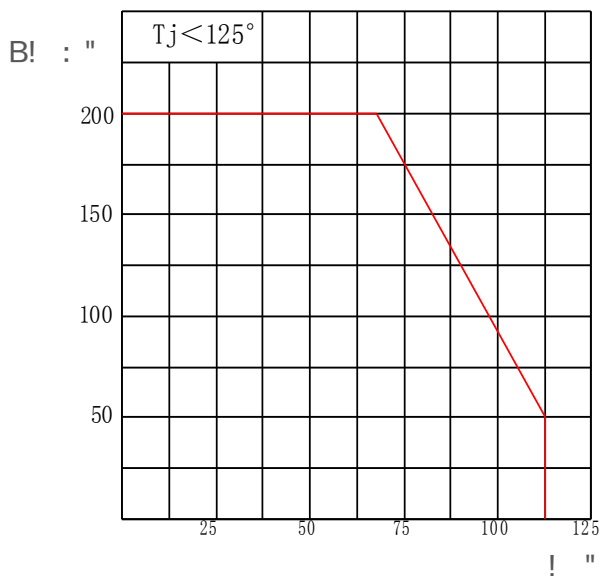

B6 ! "

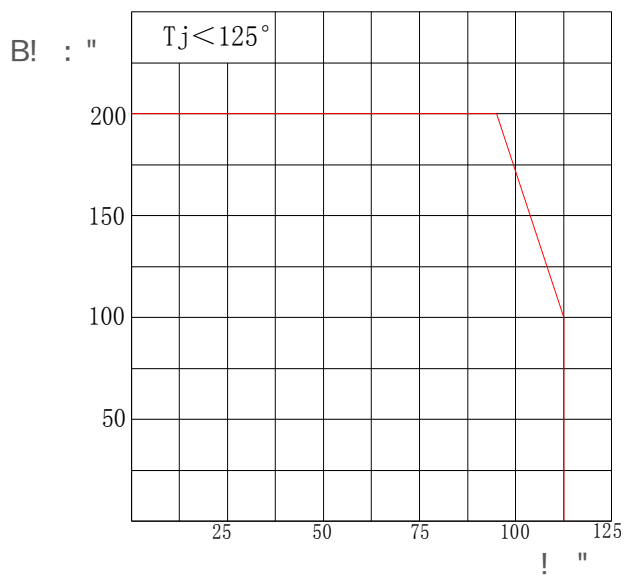

I H

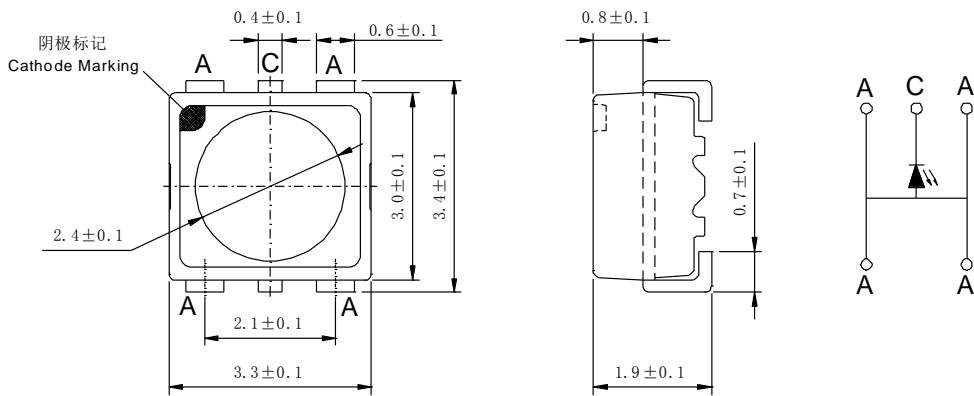

-
-
-

—
 , ;
 " A+ 7 UUR % , / B / / 1&+&- , "
 + " 7
 B / / 1&+&/ 4 A+ % H+ % GH+ % + "

GH

- :
- F
-

, ;
 " A+ 7 % . % , /
 ! B / / 1&+&- , "
 + " R I 7 MT
 ! B / / 1&+&/ - A+ % H+ %
 + GH+ % + "

I

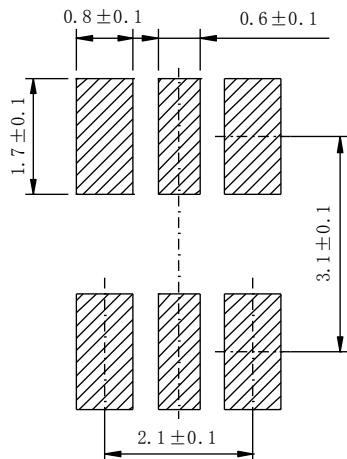

- GH
- I

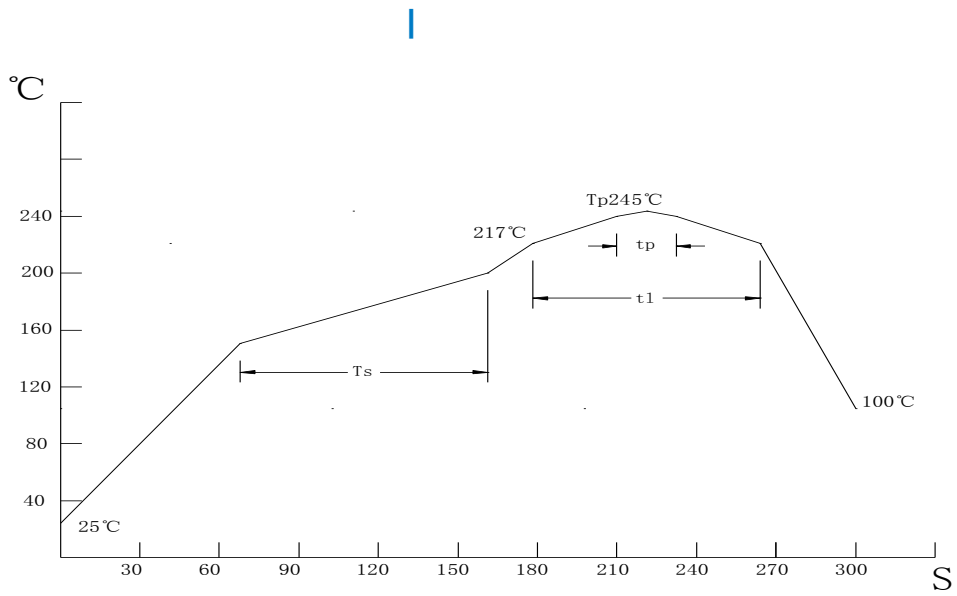

370 | & ! : " : a
 +. & | & & + , (

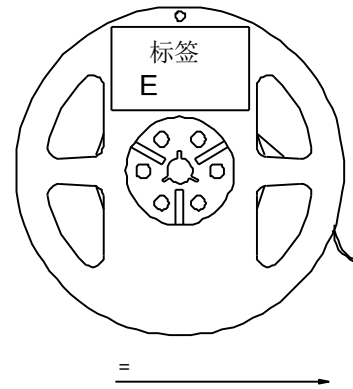
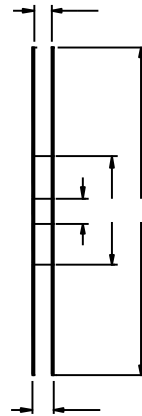
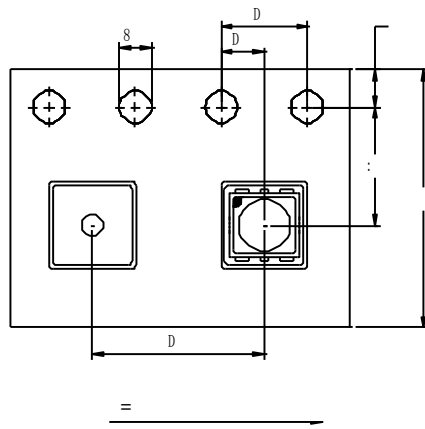

=

- / B / +1/ & % B -1 &

E - / B / +1/ & %

B -1 &=

=

1 h -h -h +h . . h 0. h , . h .

=

: + G

001 2, h , +h , .1. h + , . h +

; & &E !; | E"

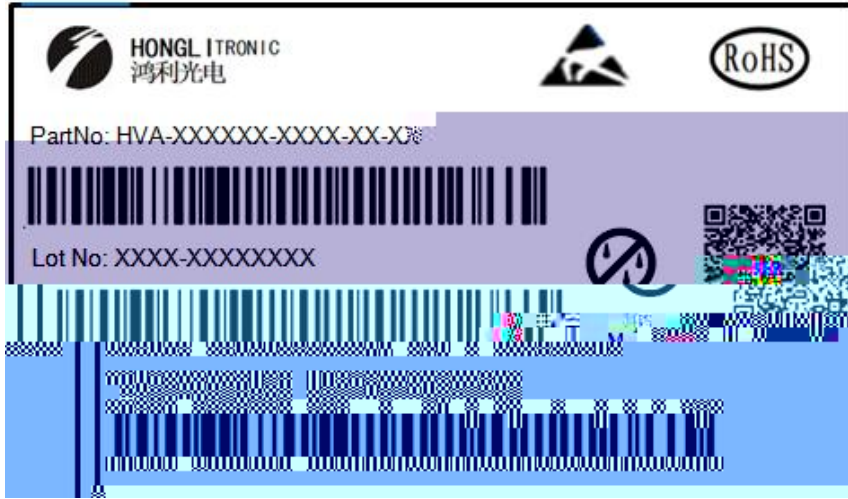

动 = | | F

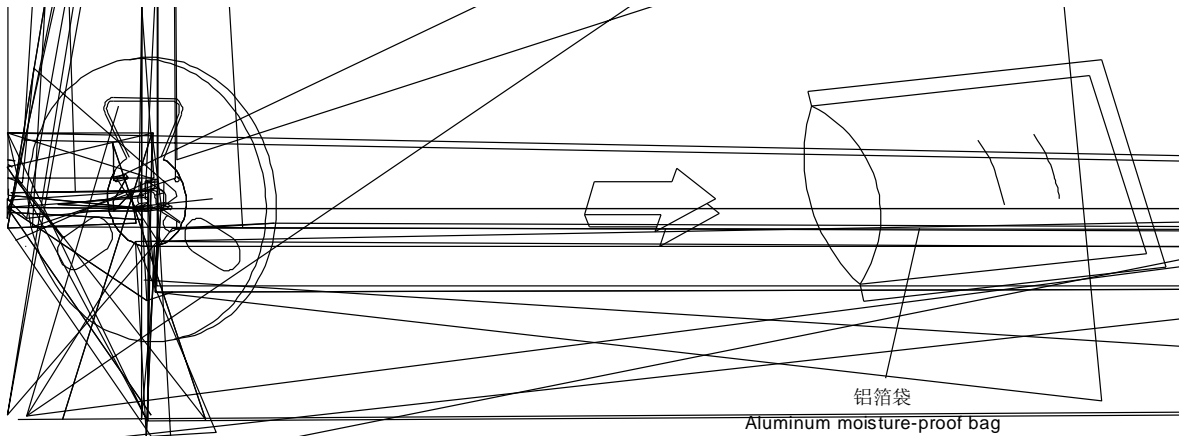

GH

动

F &

动

C =

AB !

"

&

C =

动

I

F

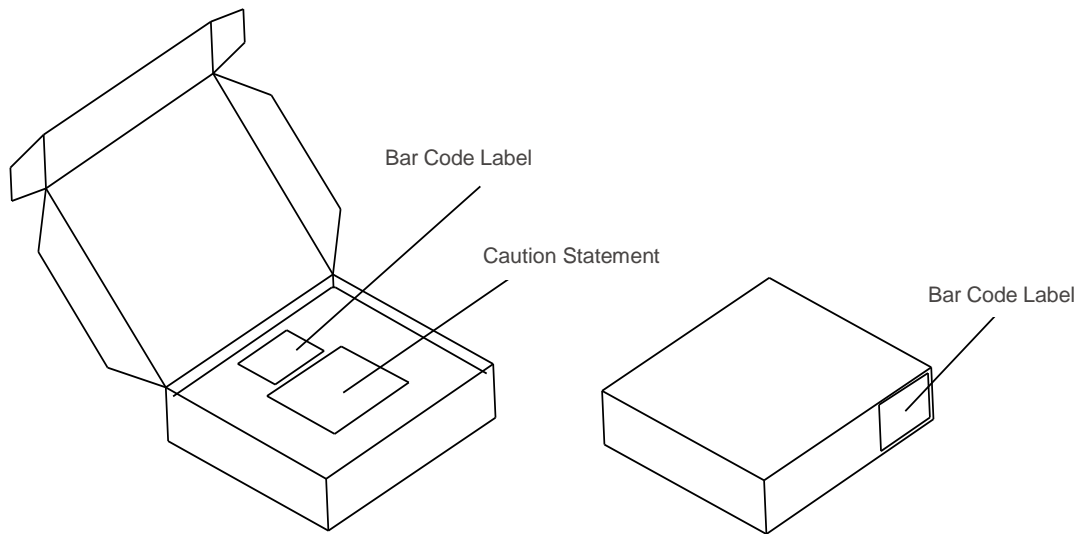

=

; ! "

E

A

+ . / h.
+ . / h.

++ , h.
++ , h.

/ + h.
+ - h.

1 % h RR h . h
@ F D6, h . h
+. h1 h
@ F D6,

出

@

F : % (

&

M UTI HG T h ; I U I I H T h ; H T 1 %
@ F 6, "

M UTI HG T h R I U I I H T h R H T +. %
@ F 6, "

; ; M UTI HG T h I U I I H T h H T, : 2 +. %
6, "

A % %